





MLT 1035 LT LSU

 **Lifting capacity**3500 kg
(load centre at 500mm from forks heels)
Tipping load at maximum reach780 kg

 **Lifting height**9.60 m
Times : unladen / loaded (in s)
Lifting6.7/7.3
Lowering5/4.7
Simultaneous extension 1st and 2nd booms ...13.6/14.8
Simultaneous retraction 1st and 2nd booms.....8.1/7.8
Crowd.....3
Dump2.5
Frame levelling of serie10°/10°

 **Tyres**
460/70-24/17,5 LR 24

 **Forks** (mm)
Length.....1200
Width X thickness.....125 x 45
Maximum distance between forks.....1260
Carriage rotation127°

 **Oil bath multidisc brakes on front and rear axles**

 **Perkins engine STAGE III A**
Turbo : 1104 D - E44 T.....4 cyl. - 4400 cm³
Power (ISO/TR 14396) :101 HP/74.5 kw
Maximum torque
(ISO/TR 14396) :420 Nm at 1400 rpm
Direct injection
Water cooling

 **Transmission**torque convertor
Reversing shift.....electrohydraulic
Number of speeds4/4
Limited slip differential lock
Max. travel speed:35 km/h

 **Hydraulic Turbo LSU**.....110 l./mn - 270 bars
Variable displacement pump
Valve bank DDIC
Monolever **J.S.M (Joystick Switch and Move)**
Flow divider with load sensing device driving and braking

 **Capacities**
Hydraulic oil125 l
Fuel tank120 l

 **Weight unladen** (with forks)7874 kg
Overall height2.30 m
Overall width2.32 m
Overall length (at forks carriage).....5.09 m
Ground clearance0.45 m
Turning radius (outside wheels)3.85 m
Drawbar pull.....8800 daN

Forward reach at maximum height : 2.75 m

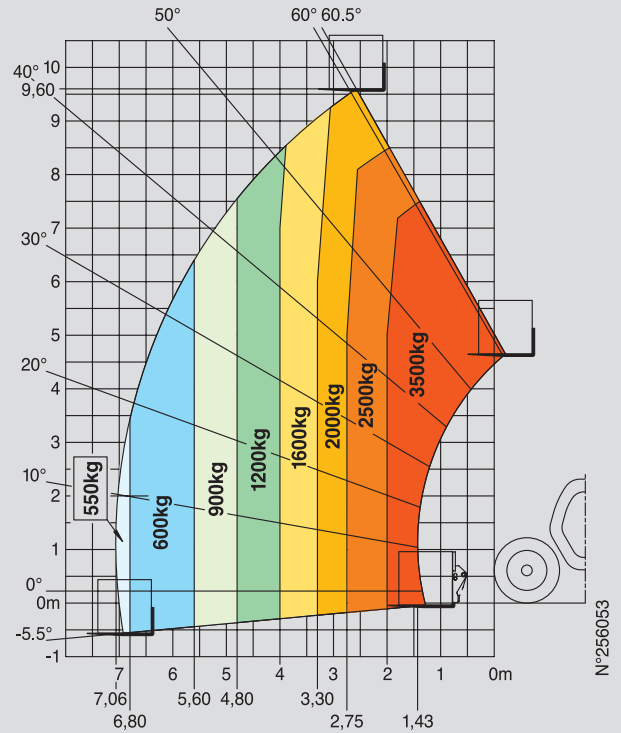

EN 1459 annexe B

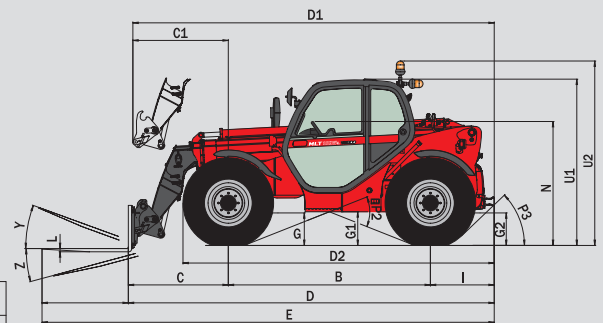

MLT 1035 LT LSU

A	1200
B	2810
C	1390
C1	1325
D	5090
D1	5025
D2	4295
E	6285
F	1870
F1	1870
G	455
G1	440
G2	440
H	10°
H1	10°
I	890
J	865
K	1260
L	45
N	1690
O	125
P2	38°
P3	45°
R	3630
S	7850
T	3610
U1	2300
U2	2550
V	4980
V1	1370
V2	3855
W	2325
X	8.2°
Y	118.5°
Z	

mm

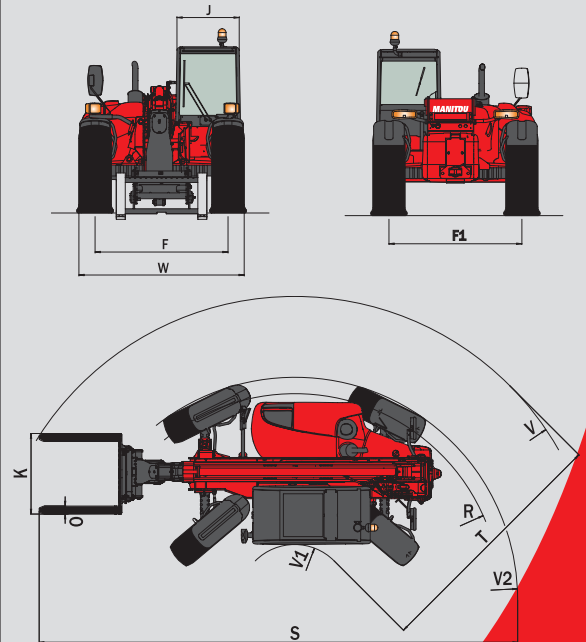

This publication in no way constitutes an offer and the company reserves the right to alter specification without prior notice.
The MANITOU models presented in this brochure can be supplied complete with optional equipment attachments.

